

SST316 worm gear hand winch

500 – 5000 kg

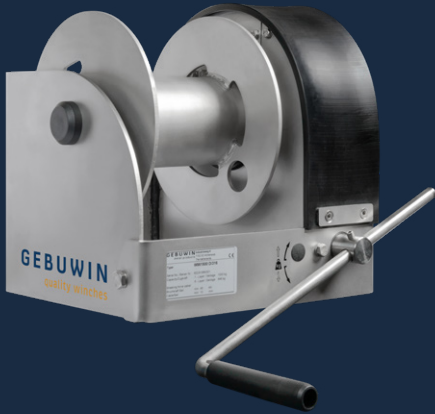

Description of the hand winch

This stainless steel winch is corrosion resistant and is completely made of stainless steel 316. The hand winch is IP54 classified which means that it is resistant to splashing water and dust on the inside. In short: a winch for the toughest conditions.

Product specifications

- > robust and safe lifting and pulling winch in compliance with EN13157
- > static safety factor 4
- > two lifting speeds
- > right angled, easy to grease worm transmission and maintenance free bearings
- > load pressure brake with double ratchet system for safe stable hold of the load in any position
- > closed gearbox to protect against environmental influence - protection classification IP54
- > cable outlet upwards, downwards or at rear
- > adjustable crank, with ergonomic grip
- > suitable for wall and floor mounting
- > large rope capacity
- > simple and quick attachment
- > full stainless steel 316 body, drum, crank and all outgoing parts
- > corrosion resistant



Options (code)

- grooved drum (GD)
- 2 drum compartment (2D) or multiple up to 8 (XD)
- suitable for floor mounting (FM)
- ATEX certified zone 2 and 22 (EX)
 - CE II 3G Ex IIC T4 Gc, -20°C<T amb <+70°C
 - CE II 3D Ex IIIC T135°C Dc, -20°C<T amb <+70°C
- custom options possible - [on request](#)

Accessories

- steel or stainless steel wire rope
- pulley block
- electric or airmotor as from WW1000



Technical specifications MR500-1500 SST

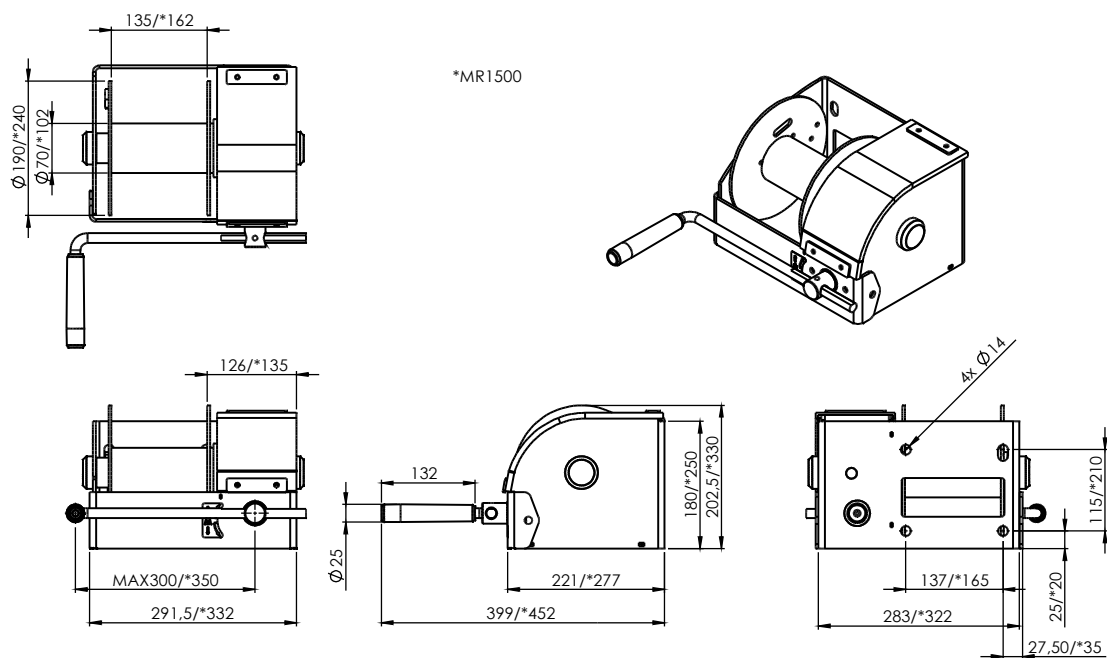

Technical specifications MR3000-5000 SST

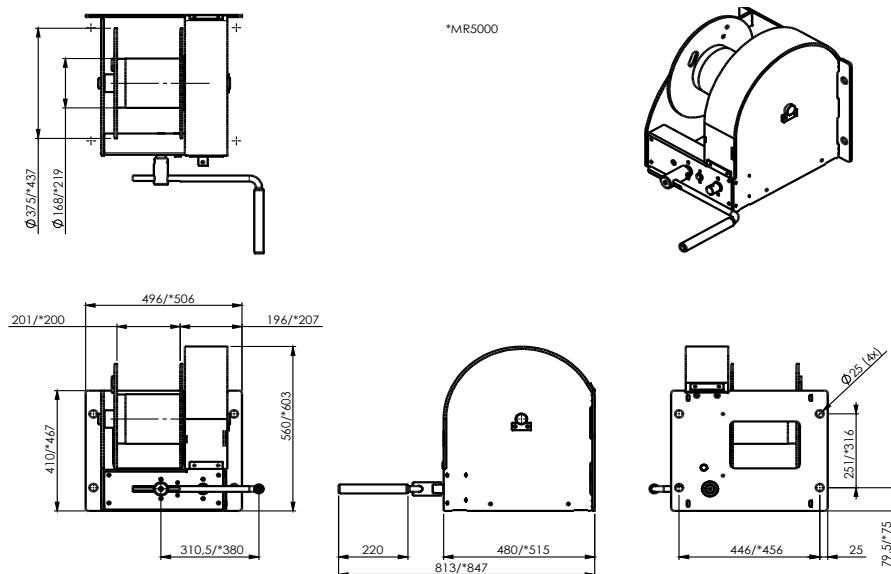

Technical specifications	Unit	MR500 SST	MR1500 SST	MR3000 SST	MR5000 SST
Capacity 1st layer	kg	500	1500	3000	5000
Capacity 4th layer	kg	326	970	2066	3485
Capacity top layer	kg	242	867	1711	3165
Rope diameter-Ø	mm	8	12	16	20
Rope storage 1st layer	m	3,2	3,2	5,2	4,5
Rope storage 4th layer	m	18,5	19,8	30,8	28,7
Rope storage top layer	m	40,2	27,3	41,9	39,4
Lift per crank rotation	mm	20	9	11 (5)	13 (3)
Crank effort at full load	daN	10	14	31 (14)	73 (15)
Weight (without rope)	kg	16	30	104	135
Article number	no.	77281367	77281882	77277090	77279090